

Job: _____

Item: _____

Quantity: _____

Universal Lug Dolly

The ideal transport/storage dolly for all departments; produce, bakery, meat, deli, etc.

Designed to hold lugs by the bottom, not by the lip, allowing you to store lugs of various sizes up to 16½"W x 9½"H x 27"L. Oval tubing extrusions allow easy-on, easy-off of product.

- Framework is constructed out of 1" x 1" x .070" wall tubing.
- Shelves are constructed out of ½"x 1¼" oval tubing.
- Uprights are reinforced with a channel to help prevent breakage from stem casters.
- Equipped with four 5" stem type swivel casters.
- Five-Year Guarantee against material defects and workmanship.
- Lifetime Guarantee against rust and corrosion.
- NSF Certified.

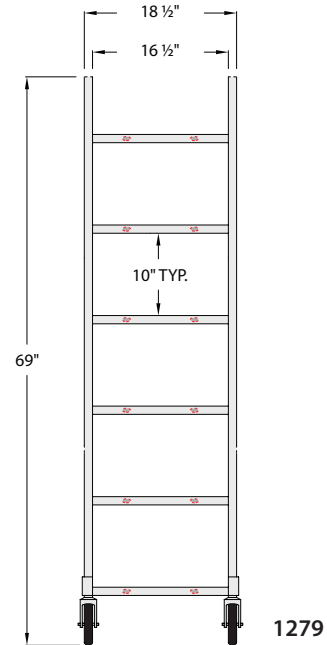

Model No.	Size W-H-D	Lug Capacity	Between Shelf Space	Ship Lbs.
1276	18½" x 36" x 26"	3	10"	26
1277	18½" x 47" x 26"	4	10"	30
1279	18½" x 68" x 26"	6	10"	35

Four 5" stem type casters (#C480).

Options:

"CL(A)" — See catalog for details.

Distributed by:

This information is for general sales and engineering use only. New Age Industrial reserves the right to modify or make changes at any time without notice to materials and specifications.

