

Job: \_\_\_\_\_

Item: \_\_\_\_\_

Quantity: \_\_\_\_\_

## 95667 - Carrier Cart

This multipurpose cart for storage and transport of food modules, boxes, pots and pans, wire baskets, and similar items. All three shelves have three lips up with front lip down. The upper two shelves are slanted 1° toward the rear to facilitate drainage.

- Shelves are constructed of .080" sheet and reinforced with a 1½" x 1½" x .070" wall tubing framework.
- Base is constructed of 1½" x 2¾" x .070" wall tubing for extra strength.
- Equipped with four, heavy-duty 6" x 2" platform type swivel casters; two with brake.
- Lifetime Guarantee against rust and corrosion.
- Five-Year Guarantee against workmanship and material defects.



Model No.	Size W-H-L	Shelf Size	No. Shelves	Shelf Spacing	Ship Lbs.
95667	20½" x 55" x 64"	20" x 60"	3	top = 17½" bottom = 18½"	100

Four 6" x 2" platform type casters — (2) swivel (#C510), (2) swivel w/ brake (#C511).

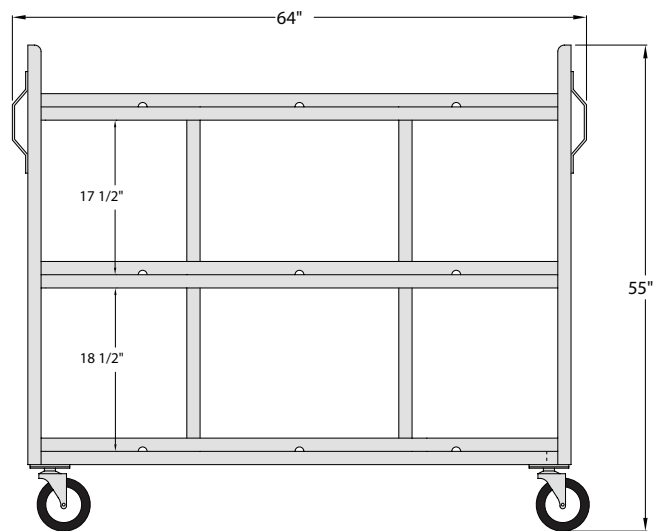
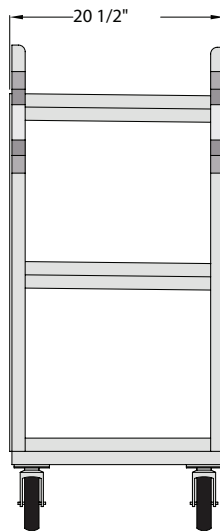

*This information is for general sales and engineering use only. New Age Industrial reserves the right to modify or make changes at any time without notice to materials and specifications.*

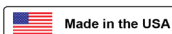

Distributed by: