

INNOVATIVE ALUMINUM SOLUTIONS

**NEWAGE
INDUSTRIAL
NEWAGE**

INSPIRATION PORTFOLIO



About New Age

At New Age Industrial, we understand the unique challenges faced in foodservice operations. We offer a comprehensive line up of aluminum storage and transportation equipment that is extruded, fabricated, and manufactured in Norton, KS. This ensures consistent quality and superior customer service for foodservice consultants and their clients.

Durability and Sanitation: New Age Industrial equipment is made from lightweight, rust-resistant aluminum, ideal for demanding foodservice environments.

Space Optimization: Our storage and transport solutions, including shelving units, racks, and carts, helps maximize space efficiency in food and beverage operations.

Customization: We specialize in customizing solutions to fit the specific needs of each client, ensuring a perfect fit for any layout.

Streamlined Operations: Our effortless experience includes expert support to help consultants choose or design the ideal equipment to improve workflow and operational efficiency for their clients.



Tom Sharp - Vice President

“Our unmatched versatility in product design and fabrication make New Age Industrial the top choice.”

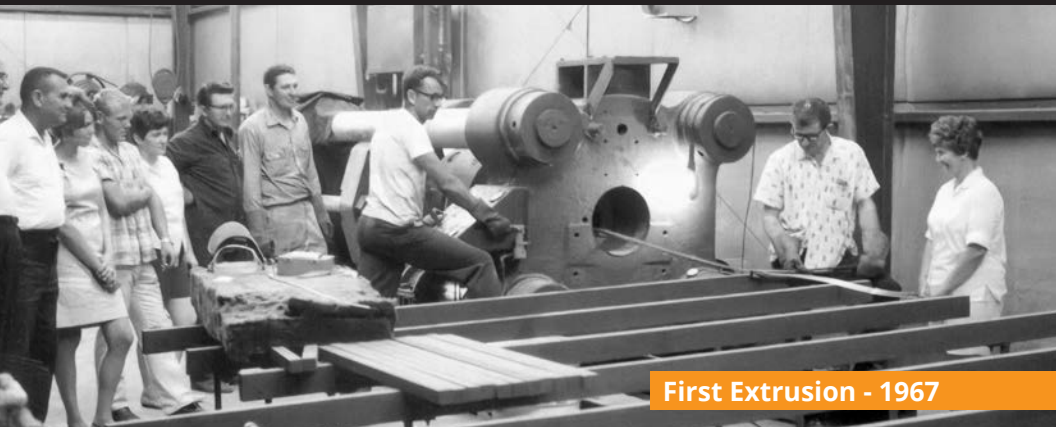

First Extrusion - 1967



What Makes New Age Different?

We understand the impact even minor adjustments can have on an entire operation. That's why we prioritize customer-friendly custom solutions. Our flexible manufacturing process grants us complete control over quality, quantity, and cost, allowing us to deliver solutions that are reliable and effective. Whether you require a slight modification to an existing product or a custom design from the ground up, we are equipped to provide high-quality solutions that optimize operations and elevate your bottom line.

1

More than just another supplier,

Our in-house extrusion press transforms primary grade aluminum billet into customized solutions that meet unique equipment needs. This process ensures unmatched design flexibility and guarantees exceptional durability in the finished product.

2

New Age maintains a vast inventory of extrusion dies, allowing us to deliver both readily available stock items and custom-built solutions that are truly unique. This coupled with our in-house design expertise, empowers us to tackle projects no other manufacturer can.

3

We are the aluminum specialists.

This singular focus allows us to develop unmatched expertise in aluminum fabrication, ensuring exceptional quality and long-lasting durability in every product we create.

“Whether it is one or ten thousand units, we will create a product that meets your needs.” - Dan Porter, Engineer

Customizing



Have An Idea

Necessity is the mother of invention, and every product we manufacture is designed to fill a need.



Write It Down

Details such as how the product is being used along with pan sizes help complete the vision.



Sketch It Out

Some of our best product ideas were first sketched out on paper napkins.

Here, a quick sketch captured the essence of the customer's desired product, along with key dimensions for a seamless start.



Submit It

**Ready to Collaborate?
Let's Make Your Vision a Reality.**

Simply email us at our dedicated address for FCSI Consultants. This will connect you directly with a custom product engineer, and our team will collaborate with you on finalizing a product design, address any questions you may have, and oversee production every step of the way, ensuring a seamless experience from concept to completion.

consultants@newageindustrial.com

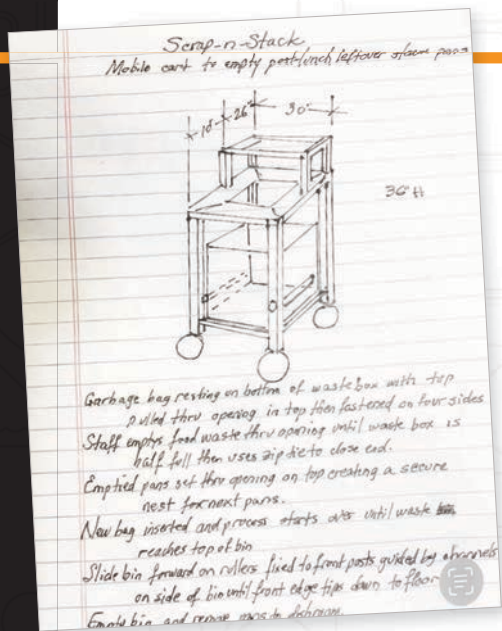

Final Drawing

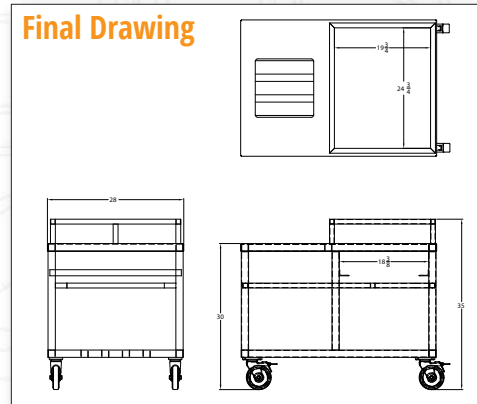



1. Tubing and angles are extruded from Primary Grade Aluminum using our extrusion press.



2. Extrusions are cut to exact length.

3. Parts are drilled, punched, bent and deburred to ensure optimal fit and finish.



4. Each piece undergoes careful inspection and measurement before welding.

5. Products are cleaned prior to final assembly, then securely boxed for safe transport.



Watch a video of the complete process.



Fish File

From Expensive Stainless Steel to Innovative Aluminum: A Customer Success Story

A distributor needed a cost-effective and efficient solution for a high-end hotel. They needed a rack that would hold Lexan containers of iced raw fish in their walk in cooler and their cook line.

They were using a stainless steel version with a very high price-point that took months for the manufacturer to deliver.

We delivered a custom-designed aluminum alternative at half the price, offering several key advantages:

Cost Savings: The aluminum construction significantly reduced the cost compared to stainless steel.

Fast Turnaround: Production time was dramatically shorter compared to the previous solution.

Enhanced Functionality:

Drainage System: Each shelf was angled slightly towards the back, channeling melted ice into a removable drip pan for easy cleaning.

Concealment: A stylish solid sheet back hid the raw fish containers on the open concept restaurant's cook line, maintaining a clean aesthetic.

High-Volume Orders: The hotel's satisfaction led to repeat orders of eight units at a time.



99554



Removable drip pan for easy clean up.



Each level/shelf is slightly angled to the back to promote drainage.



Catering Carts

From Wobbly Deliveries to Satisfied Customers: A Custom Cart Solution

A California Chicken Concept faced frustration with damaged deliveries. They were using a small, foldable cart in employee cars to transport catered lunches. Unfortunately, these boxes weren't stable, leading to spills and ruined meals.

We listened to the client's needs and designed a custom cart specifically for their catering boxes. This innovative cart offered several key advantages:

Perfect Fit: Designed to perfectly support their specific box size, eliminating instability and damage.

Easy Transport: Lightweight construction allows for effortless lifting and maneuvering.

Space Saver: Removable handles detach for a compact design, fitting seamlessly into standard vehicles.

Effortless Loading: Handles double as support during delivery and lift off for easy loading and unloading.

Built-in Protection: A full perimeter bumper safeguards walls and fixtures during deliveries.

Customizable: Adaptable to accommodate a variety of box shapes and sizes for future needs.

By investing just \$30 more than the previous solution, the California Chicken Concept eliminated damaged deliveries and ensured satisfied customers.



98752



Boxes are fully supported on the bottom and sides.

Perimeter Bumper

Effortless Catering: The All-in-One Solution for Busy B&I Facilities

Many B&I foodservice facilities cater for employee meetings and lunches. This cart was designed after a catering cart ran away from an employee; Crashing into an executive's very expensive automobile.

This all-in-one cart eliminates the hassle of multiple trips and ensures that catering supplies arrive safely and organized. Whether it's for employee meetings, lunches, or corporate events, this cart empowers B&I foodservice teams to deliver exceptional service with ease.

Organized Storage: Compartmentalized shelves keep all your catering supplies – folding tables, glass racks, coffee urns, sheet pans, and more – neatly organized and readily accessible.

Effortless Maneuvering: The cart's easy-grip handle and quiet rolling casters allow for smooth navigation, even in tight spaces.

Enhanced Safety: A built-in hand brake (dead man's brake) ensures immediate stopping power for added control and peace of mind.

Perimeter Protection: A full perimeter bumper safeguards walls and furniture during transport.



51564



Table Latch | Hand Brake



Pan Storage | Bins



Chicken Station

From Sketch to Solution: Customizing for Efficiency

A popular sandwich chain reached out with specific requirements for a breasting station with specific requirements for an upcoming new roll-out.

The original drawing was a hand line drawing along with container specifications. There were several revisions to get to the final design.

This customized solution underwent successful field testing, demonstrating its functionality and effectiveness. The customer decided to go a different route that didn't require a cart when projections were lower than anticipated.

The cart went through several revisions to ensure it perfectly accommodated the:

- Type of containers needed.
- Size and quantity of containers required.
- Visibility and Ease of Access:
Our fabricators cleverly bent each section to secure the containers while keeping them readily accessible.



53155

Container Specs

Item	Qty	Description
6	2 ea	Food Storage Container Cover Cambro RFS6SCP190 (0.450 lbs total. Packed: 12 ea) Food Container Seal Cover, for Camwear® 6 & 8 qt. round storage containers, translucent, polypropylene, NSF
Total for Item 6		
15	1 ea	Food Storage Container Cambro RFS6PP190 (0.883 lbs total. Packed: 12 ea) Storage Container, round, 6 qt., 9-15/16" dia. x 7- 15/16" H, translucent, polypropylene, NSF
Total for Item 15		
16	1 ea	Food Pan Cambro 36CF148 (5.375 lbs total. Cube: 0.34. Packed: 1 ea) ColdFest® Food Pan, 1/3 size, 6" deep, ABS plastic shell with FDA listed non-toxic gel core, stackable, white, NSF
Total for Item 16		
	1 ea	30CFC135 ColdFest® Food Pan Cover, 1/3 size, flat, polycarbonate. clear. NSF

Customer Drawing



Preliminary Drawing

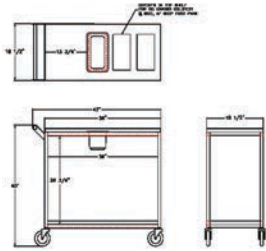

REVISIONS		SUB. OR. 2020	MODEL # 0267200C (Rev. 02/09) POLY-DIPPER UTILITY CART, 3 COMP © 2009 NewAge Industrial, Inc. MADE IN U.S.A.

Final Drawing

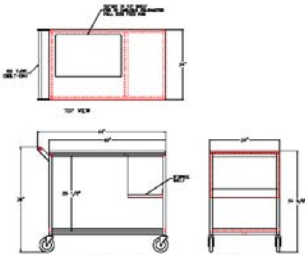

REVISIONS		SUB. OR. 2020	MODEL # 0267200C (Rev. 02/09) POLY-DIPPER UTILITY CART, 3 COMP © 2009 NewAge Industrial, Inc. MADE IN U.S.A.

Institutional Carts

Flex Tray Drying Made Easy: A Custom Solution for Correctional Facilities

Many correctional facilities utilize the Flex Tray system for food service. However, drying these flexible silicone trays presented a challenge for one of our correctional distributor partners.

Our design team collaborated with the distributor to create a custom drying rack.

This innovative rack streamlines the drying process for Flex Trays, saving valuable time and resources for correctional facilities.

Efficient Drainage: The precisely angled design allows water to drain effectively, preventing pooling and promoting faster drying.

Secure Hold: The custom-bent aluminum sheet securely holds the trays in place, even when loaded straight from the dishwasher.



99452





Streamlined Sliced Meat Delivery for Renowned University

Designed for Ohio State University, this lug dolly simplifies the transportation of sliced meats and cheeses across their campus from a central commissary.

This simple yet highly functional design has proven its value over time. Ohio State University continues to rely on these Lug Dollies, demonstrating their lasting contribution to their foodservice operations.

Secure Transport: A locking strap keeps the lugs securely in place, ensuring safe product delivery.

Efficient Use of Space: The rear pan stop, welded for durability, prevents product from shifting during transport.



99367

Donut Display

A Brighter Solution for Donut Displays

This cart was designed for a donut chain in Chicago. They were looking for rolling carts to fit their mill work displays.

Unlike their previous carts, which took months to arrive from Italy and offered limited features, this New Age solution boasts several advantages:

Faster Delivery & Local Support:

We delivered the carts significantly faster, eliminating the long wait times associated with overseas suppliers.

Enhanced Value: Our competitive pricing slashed the cost in half compared to their previous solution.

Eye-Catching Appeal: Integrated LED lights illuminate the donuts, creating a more captivating display for customers.

Storage Efficiency: An additional compartment provides dedicated space for donut bags, keeping the presentation area organized.

Sleek & Seamless Design: Powder coating delivers a smooth, high-quality finish that complements the display case. The wiring for the LED lights is cleverly hidden within the uprights, maintaining a clean aesthetic. For added convenience, the power supply is discreetly mounted within the base, which also doubles as additional storage.



52606



LED Light Bars

Donut Bag Storage & Power Supply

NOTE: RACK GETS POWDER COATED
AND REQUIRES LED LIGHT BARS
MOUNTED ABOVE EACH SHELF
LIGHT WIRING RUNS DOWN BACK SIDE
OF TUBE WITH LEG UPRIGHTS

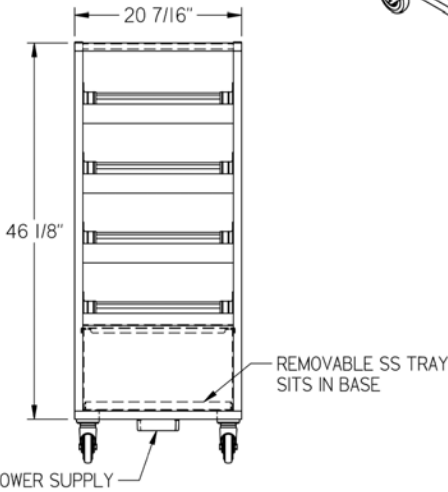
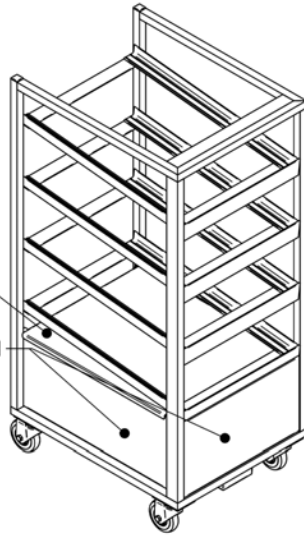

WHAT ARE YOU WAITING FOR?

Contact Us TODAY!

NEW AGE
INDUSTRIAL
NEW AGE

New Age Industrial

16788 US Hwy 36

PO Box 520

Norton, Kansas 67654

800-255-0104

NewAgeIndustrial.com