

## MODULAR EQUIPMENT STAND ASSEMBLY INSTRUCTIONS

### Materials:

- (2) Solid Top “Shelves”
- (4) Posts
- (1) 3/16” Allen Wrench
- (8) Hex Plugs

Do NOT use a hammer. Damage to equipment will void all guarantees.

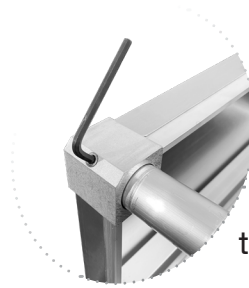

- 1) First, check the corner clips of each shelf.

The set screws may need to be backed out, *not removed*, to allow the posts to pass through.

- 2) Stand each shelf upright on the longest edge, 90° to the floor or another flat surface. Align the corner clips.

*Some prefer to attach the top shelf to the first post then slide each additional shelf into position.*

- 3) Slide the first two posts, from bottom to top, through the corner clips of each shelf. It is recommended to start with the clips opposite the flat surface, in order to access the set screws in each clip. Tighten each screw.

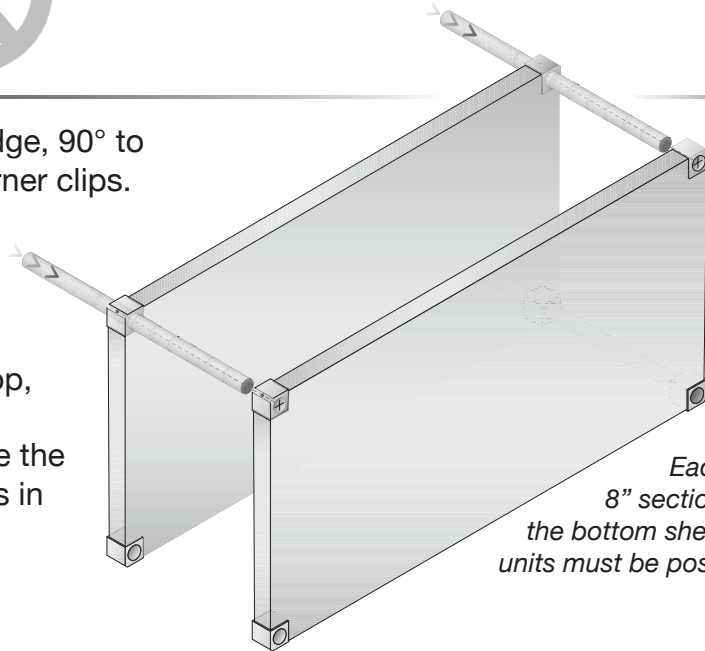

*Each post has an 8” section on one end, the bottom shelf of stationary units must be positioned above this section.*

- 4) Carefully flip the unit over, repeat Step 3.

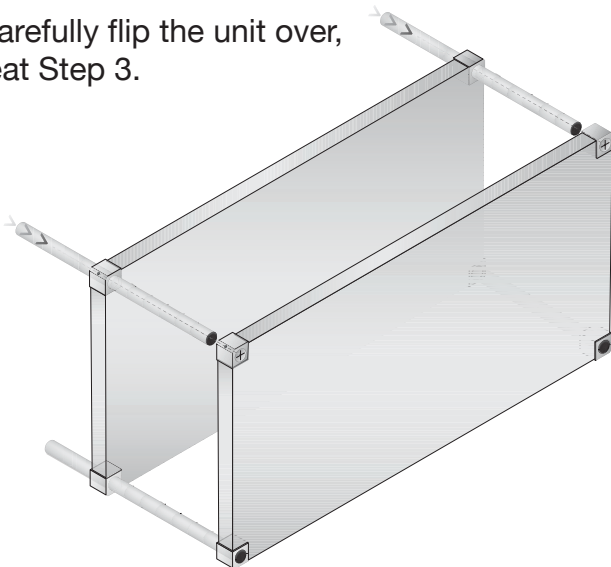

Once all four posts are inserted, stand the unit upright.

To level or stabilize a unit, loosen each set screw — on one post at a time — to allow the post to correct itself with the unit. Retighten the set screws and repeat the process for uneven posts until the table is stable.



- 5) Once the framework is completely assembled, insert a hex plug into every set screw for NSF Compliance.