

STANDARD EQUIPMENT STAND ASSEMBLY INSTRUCTIONS

GSCU

Materials:

- (1) Removable Top
- (1) Table Top Frame
- (1) Removable Undershelf
- (1) Lower Support Frame
- (4) 24" Posts
- (1) 3/16" Allen Wrench
- (8) Hex Plugs



Do NOT use a hammer. Damage to equipment will void all guarantees.

1) First, check the corner clips of each shelf.

The set screws may need to be backed out, *not removed*, to allow the posts to pass through.

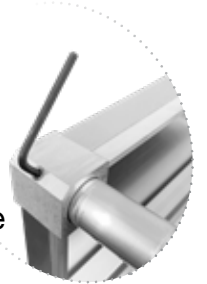

2) Each post is marked in 2" increments for simplified assembly, the bottom of each post has an 8" section; using a pair of pliers, remove the bottom cap of each post.

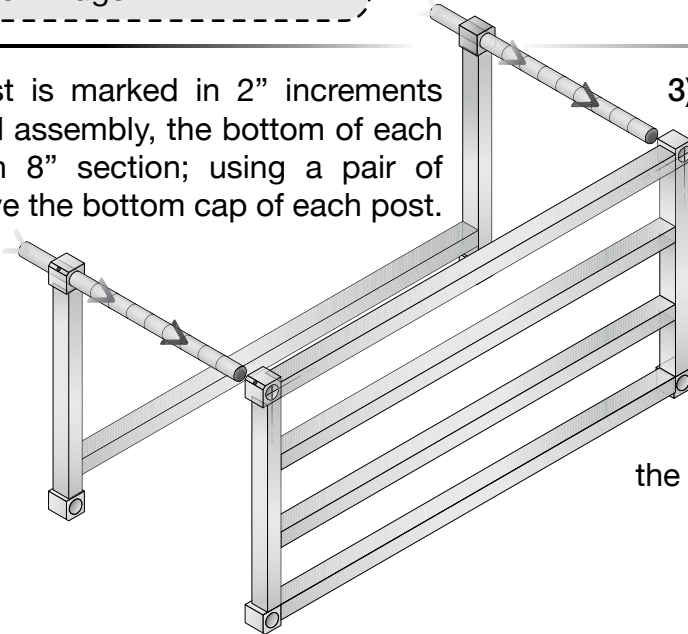

3) Stand each shelf upright on the longest edge, 90° to the floor or another flat surface. Align the corner clips.

Some prefer to attach the top shelf to the first post then slide each additional shelf into position.

4) Slide the first two posts, from bottom to top, through the corner clips of each shelf.

It is recommended to start with the clips opposite the flat surface, in order to access the set screws in each corner. *Tighten each screw.*

Notice: The Table Top Frame has a top and a bottom, make sure to position all pieces to create a flat top.

5) Carefully flip the unit over, repeat Step 4.

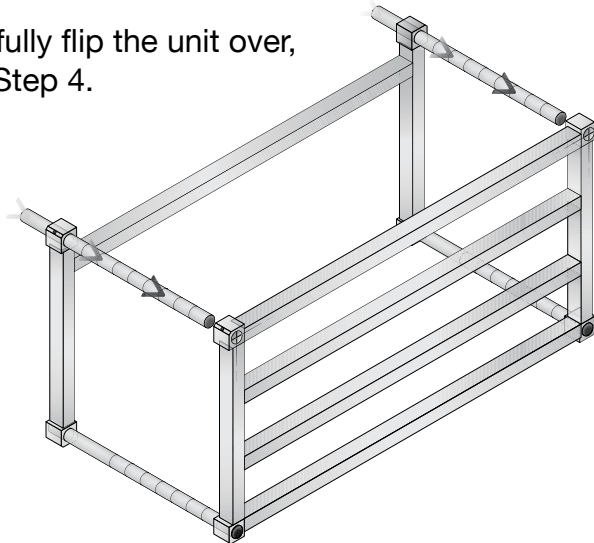

Once all four posts are inserted, stand the unit upright.

To level or stabilize a unit, loosen each set screw — on one post at a time — to allow the post to correct itself with the unit. Retighten the set screws and repeat the process for uneven posts until the table is stable.

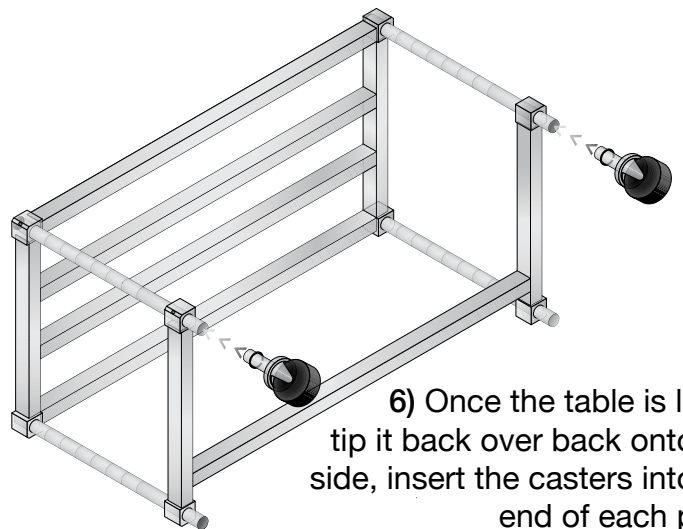

6) Once the table is level, tip it back over back onto the side, insert the casters into the end of each post.

Roll the unit over again to simplify installing the second pair of casters.

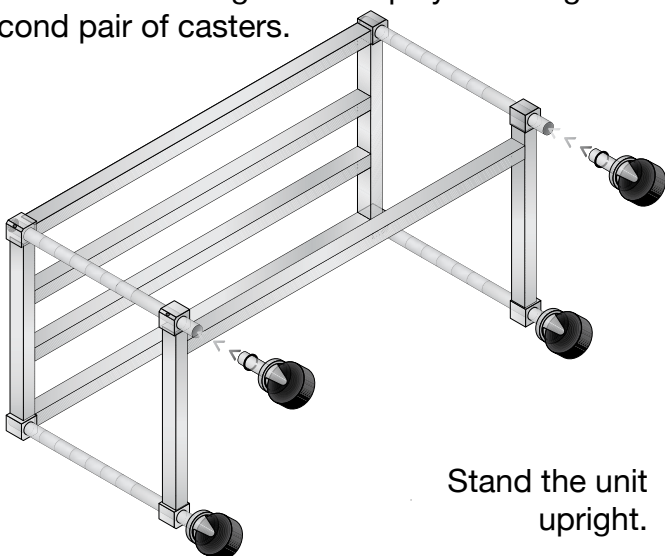

Stand the unit upright.

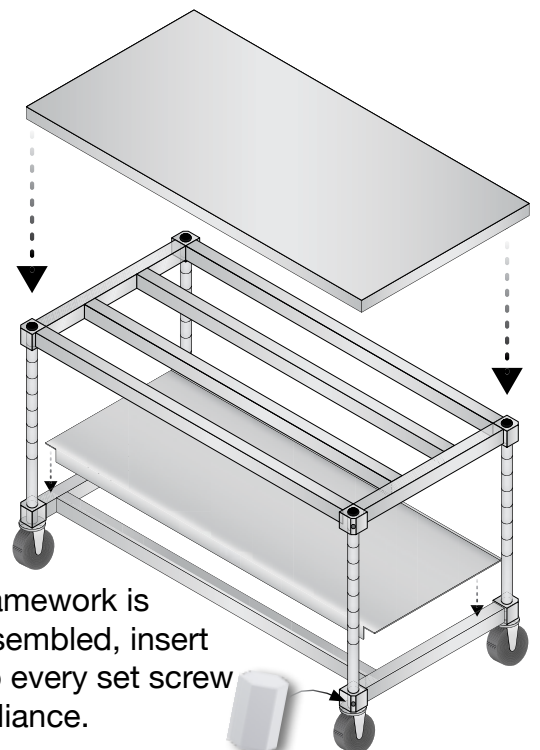

7) Once the framework is completely assembled, insert a hex plug into every set screw for NSF Compliance.

Place the solid top and undershelf.