

Job: \_\_\_\_\_

Item: \_\_\_\_\_

Quantity: \_\_\_\_\_

## 98012PC || Three-Tier Picking Cart

This cart is ergonomically designed for picking. The flat shelf design makes and easy on-off application for the containers. The desk/end shelf is designed to hold pick sheets and is ideal for this cart.

- Framework is constructed out of 1½" x 1½" x .070" wall tubing.
- Shelves are constructed out of 1¼" x 1½" x .070" wall tubing with 1¼" x 2 ¼" x .100" wall T-Bar.
- Desk/side shelf is constructed out of 18GA steel sheet and powdercoated.
- Equipped with four 5" platform type swivel casters.
- Lifetime Guarantee against rust and corrosion.
- Five-Year Guarantee against workmanship and material defects.



Model No.	Size W-H-D	Shelf Spacing	Ship Lbs.
98012PC	48" x 42½" x 22"	15"	100

Equipped with four 5" platform type swivel casters (#C450).

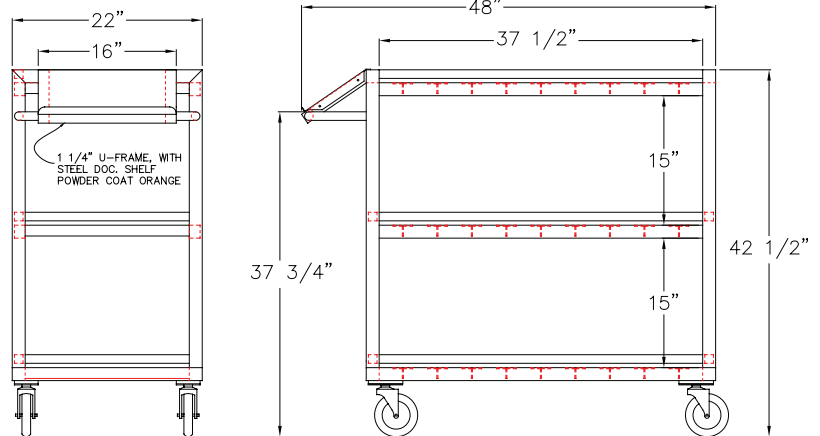

*This information is for general sales and engineering use only. New Age Industrial reserves the right to modify or make changes at any time without notice to materials and specifications.*

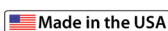

Distributed by: